

iCONstant flex

Continuous Ventilation -
suitable for any wet room



KEY FEATURES

- Selectable trickle flow rates 18 / 29 / 40 / 47 / 58 m³/h. Boost up to 72 m³/h
- From 15.4dB(A) the quietest dMEV fan available
- Very low running cost
- IPX5 – Install in Zone 1 and 2
- Timer and Humidity versions. Two minute delay start (boost) option
- Memory retained in event of a power cut
- 3 year warranty

Based on our very successful iCON brand, we have developed the quietest dMEV fan available for toilet, bathroom, utility room and kitchen installation bringing incredibly low sound levels to this market sector. The fan is perfect in the kitchen too. Utilising the very latest motor technology and incorporating advanced features we have been able to produce an energy efficient fan that will help eliminate the problems of condensation by continuously extracting the damp air that is the source of the problem.

The iCONstant flex boasts features that reduce human intervention and ensure the fan is always operating at the optimum level. This is perfect for the social housing sector where specifiers, landlords and tenants all seek a ventilation solution that is energy efficient, economical to run and quiet to operate.

iCONstant flex, the virtually silent, low energy dMEV fan from Airflow – packed with features – results guaranteed.

MODELS

Timer	On boost timer can be set to run on for 2, 15, 30 or 40 minutes
Humidity Timer	Intelligent humidity sensor adjustable between 60% and 90%. On boost timer can be set to run on for 2, 15, 30 or 40 minutes

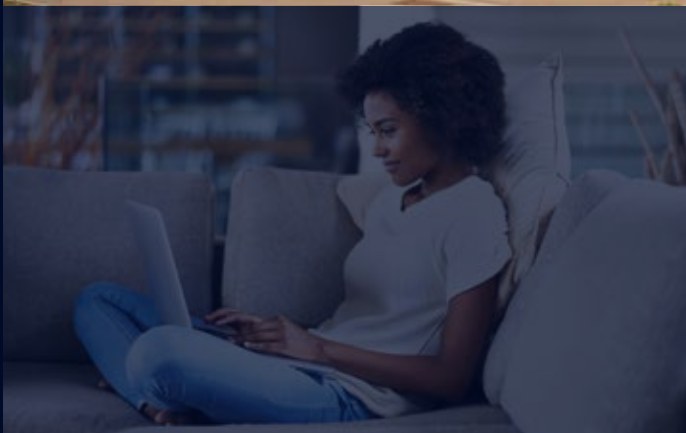

TECHNICAL DATA

Specification	iCONstant flex				
Air flow m ³ /h (trickle/boost)	18 / 29	29 / 40	40 / 47	47 / 58	58 / 72
Air flow l/s (trickle/boost)	5 / 8	8 / 11	11 / 13	13 / 16	16 / 20
Fan type	Axial				
Controls	Timer or Humidity & Timer				
Sound pressure dB(A)@3 m	15.4 / 21.6	21.6 / 26.8	26.8 / 31.0	31.0 / 32.6	32.6 / 39.9
Power watts	1.26 / 1.51	1.51 / 1.79	1.79 / 1.96	1.96 / 2.54	2.54 / 4.42
Amps	0.014 / 0.015	0.015 / 0.018	0.018 / 0.019	0.019 / 0.027	0.027 / 0.037
Calculated Specific Fan Power (SFP)	0.25 / 0.19	0.19 / 0.16	0.16 / 0.15	0.15 / 0.16	0.16 / 0.22
Building Regulations ADF	Yes				
Duct diameter (mm)	100				
Voltage	100/240 V - 50/60 Hz				
Rating (wall and ceiling)	IPX5				
Weight (kg)	0.55				
Dimensions (H x W x D) mm	197 x 197 x 120				
Part No.	72687119 (T)		72687120 (HT)		
EAN Barcode	5019009332055		5019009332062		

SAP PERFORMANCE

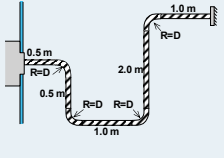
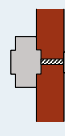
Unit configuration	Location	Flow rate	Specification fan power (W/l/s)
In room 	Kitchen	13 l/s	0.19
	Wet room	8 l/s	0.22
Through wall 	Kitchen	13 l/s	0.15
	Wet room	8 l/s	0.19

source: BRE



Cover removed showing LED self diagnostics and optional functionality buttons of flow rates fine tuning. This function can be very useful during commissioning.

DIMENSIONS

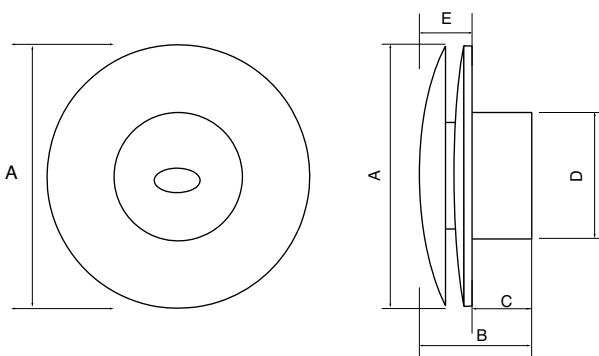

Model	A	B	C	D	E
iCONstant flex	197	120	70	100	50

PERFORMANCE

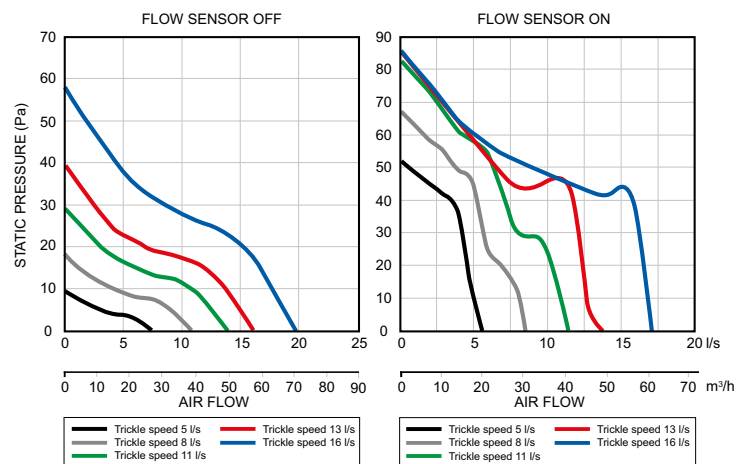

iCONstant flex

Continuous Ventilation -
suitable for any wet room

Why dMEV?

In the Building Regulations dMEV is often referred to as decentralised Mechanical Extract Ventilation. The Airflow iCONstant flex dMEV continuous ventilation fan will provide the perfect solution for both new build and retrofitting into any domestic home, particularly where there has been

an increased level of insulation making it more airtight or the homeowner / tenant has a particular problem with condensation or mould. The iCONstant flex with Timer or Humidity Timer functionality are also recognised on SAP PCDB.

Economical to Operate – less than a light bulb

iCONstant flex has been developed to consume minimal energy using a highly efficient 24 V DC motor. The motor draws a mere 1.26 W* on the lowest trickle speed of 5 l/s. The boost speed on the humidity version is intelligently controlled so as to minimise the period of the boost flow

and not significantly ramp up running costs. The yearly running cost of the iCONstant flex is just over one pound - operating at 5 l/s. This is less than a low energy light bulb if left on 24 / 7 - a small price to pay to ensure the well-being of the occupier and help preserve the fabric of the building.

Simple Controllability - optimising your ventilation

On the timer version, the boost speed can be set to run on for between 2 and 40 minutes. With the humidity timer version, the intelligent humidity sensor will activate the boost speed when the set point is reached – this can be

adjusted anywhere between 60% and 90%. When the humidity level falls below the set-point again, the fan will revert to the trickle speed. Boost speed can be activated by the integral pull cord or by a remote switch (optional).

Versatile Applications - one fan for all rooms

iCONstant flex dMEV fans can be used in any of the wet rooms. The required trickle rate is selected by the installer when the fan is fitted – this is dependent on the application - for toilets select 6 l/s, en-suites, bathrooms and utility rooms select 8 l/s and for kitchens it is 13 l/s. The boost speed will be the next speed level up with a maximum speed of 20 l/s. The boost to the higher speed is activated by one of the following methods; integral momentary pull cord, remote switch (optional) or intelligent humidity sensor. Should there be a power interruption in the property, the settings will be maintained.

Another Stylish Design from Airflow

iCONstant flex's circular design is based on our very successful iCON brand of extractor fans. Customers like our circular design as this enhances the style and appearance of the room plus a round fan is simple and quicker to install. The iCONstant flex is designed to be recessed into the wall / ceiling.

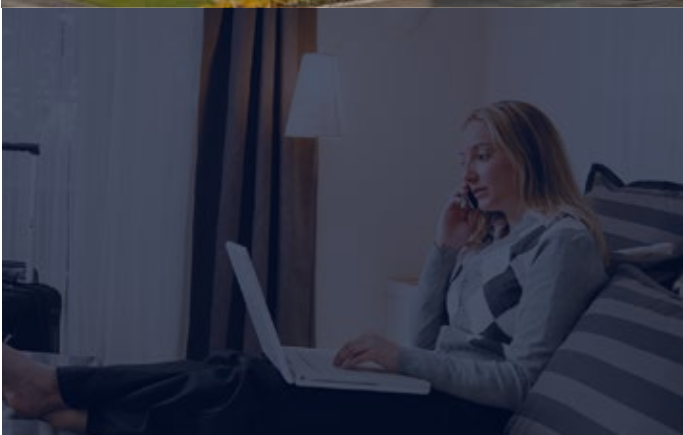

Packed with useful features with the user in mind

Airflow's intelligent humidity sensor offers the additional feature of being able to recognize a rapid increase in humidity and activates the boost speed before the pre-set value is reached so that preventive ventilation commences. Should this occur, the fan reverts to the trickle speed when the humidity level is within 10% of the set-point. The benefits of this are that energy consumption is kept to a minimum and noise levels are reduced whilst ensuring optimum ventilation is achieved, before excessive condensation occurs.

Another feature is the ability to delay the start of the boost function by two minutes. This is particularly advantageous for those quick visits during the middle of the night. The boost activation by the pull cord and humidity sensor is instant.

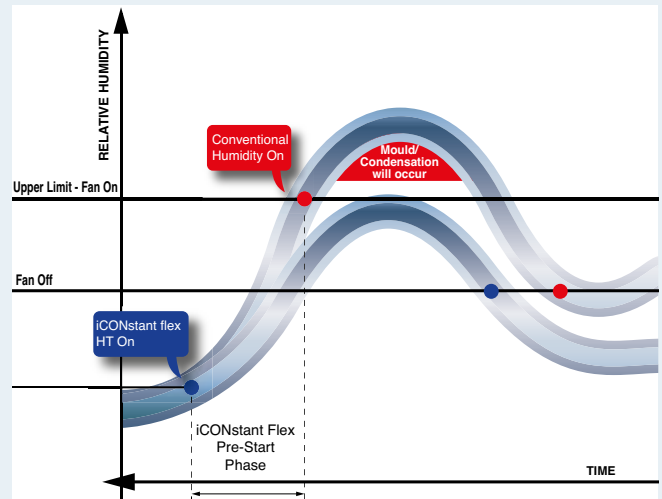

Cutting Edge LED Setup

The iCONstant flex is fitted with a unique setup diagnostic LED light. This self proving technology facilitates the set-up process and the storage of settings. Flow settings are made by the simple adjustment of the DIP switches. Installers will find it easy to setup saving time and money.

Constant Volume Guaranteed

The iCONstant flex is fitted with a flow sensor to continually monitor flow. Should conditions change, such as on a windy day, the fan will automatically adjust the flow rate to the original settings thus ensuring constant extraction is maintained. All this with no human intervention - exactly what specifiers and landlords are looking for.

Ensuring Installer Performance

The everyday running rate can be adjusted if required, up to the maximum speed of the fan by simply pressing the +/- buttons. This 'fine tuning' is very useful during commissioning to overcome system back pressure and ensure the installed performance for the installation is maintained.

User Safety is our Priority

As we have achieved IPX5 ingress protection rating on this product, you will be able to fit the iCONstant flex anywhere within Zones 1 and 2* of your bathroom/ ensuite. This makes our product incredibly safe to operate which is another reason for housing associations and landlords to specify iCONstant flex, also it is easy for the installer to position the fan. Airflow is the only supplier to offer a dMEV product for both wall and ceiling installation with this IP rating.

* Wired in accordance with IEEE wiring regulations 17th edition

CONTROLS & ACCESSORIES



Ø100mm x 3M Flexible Duct Kit - Terracotta
No: 72643601

A kit for attaching 3M flexible ducting to a fan and a square terracotta grille.



Ø100mm x 3M Flexible Duct Kit - White
No: 72643602

A kit for attaching 3M flexible ducting to a fan and a square white grille.



Cavity Wall Kit Terracotta
No: 72643201

Cavity Wall Kit with a 100mm diameter rigid duct, and attractive grille and screws in terracotta.



Cavity Wall Kit White
No: 72643202

Cavity Wall Kit with a 100mm diameter rigid duct, and attractive grille and screws in white.

Others products available from airflow.com

Call: 01494 525252

Visit: airflow.com



Airflow Developments Limited
Aidelle House, Lancaster Road,
Cressex Business Park,
High Wycombe, Buckinghamshire,
United Kingdom, HP12 3QP

E-mail: info@airflow.com
Telephone: +44 (0) 1494 525252

airflow.com

© Airflow Developments Limited. Airflow Developments Limited reserve the right, in the interests of continuous development, to alter specifications without prior notice. All orders are accepted subject to our conditions of sale which are available on request



80001456 - Issue 2 12/24